

semi-automatic
pallet stretch wrap equipment
for high-volume operations

muller 500 SERIES

the advanced technology and
engineering of high performance
muller automatic equipment



The Muller 500 Series is part of the new generation of semi-automatic equipment created through advanced Newtec technology. The 500 Series is engineered to give the high performance and operating economy associated with Muller automatic equipment.

muller 500 SERIES

semi-automatic pallet stretch wrap equipment for high-volume operations

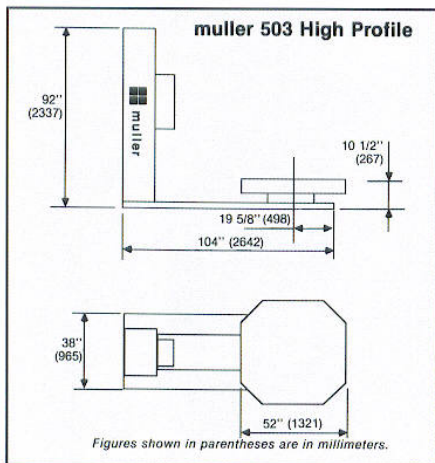
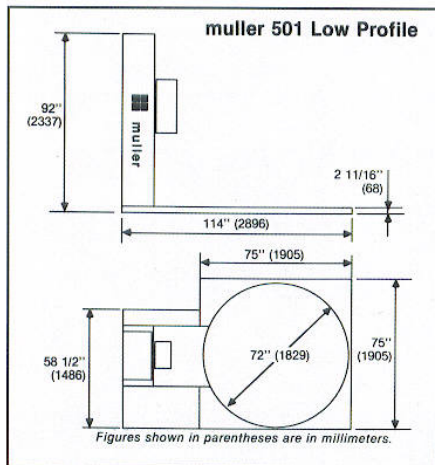

STANDARD FEATURES

Varistretch™ 2000 SR Prestretch System (patent pending)

- Self adjusting
- 20" film width
- Easy threading
- Film-dancer control
- Ratios from 65% to 400%
- Film-force tension control
- Post-stretch adjustment

Formed, heavy-duty, steel base
Programmable controller

Turntable

- 0-12 rpm adjustable from the control panel
- #50 chain drive
- Positive position alignment
- Turntable jog

Carriage

- Variable speed adjustable from the control panel
- Dual #40 chain drive
- Carriage jog

Separate top and bottom wrap counters

Automatic load-height sensor

Movable with forklift

TECHNICAL SPECIFICATIONS

Pallet size:

- 52" x 52"

Maximum load size:

- 54" w x 54" l x 84" h

Capacity:

- 5,000 lbs. dynamic

Power requirements:

- 120V/1 ph/60 Hz/15 amp

OPTIONS

- Pallet-jack loading ramp (501)
- Extended base
- Extended tower
- 30" carriage
- Dual Turntable

SHIPPING

2,600 lbs.

Shipped fully assembled

muller stretch wrap division

newtec
international

Muller Inc.
136 Weldon Parkway
St. Louis, MO 63043
Tel: 314-567-5220
Fax: 314-567-1320

Muller Ltd.
845K Tecumseh Blvd., D.D.O.
Montreal, Que. H9R 4T8
Tel: 514-685-3160
Fax: 514-685-3167

Muller Packaging Inc.
20 Staffern Drive
Concord, Ont. L4K 2Z7
Tel: 416-663-6455
Fax: 416-738-6452

Emballages Muller Inc.
191 Brunswick Blvd., Pte-Claire
Montreal, Que. H9R 5N2
Tel: 514-697-8502
Fax: 514-697-4597

DISTRIBUTED BY: