

Turntable Series Stretch Wrappers

RAPTOR[®]

525 *Semiautomatic*



- Wraps up to 35 loads per hour
- 4,000 pound capacity
- Lift truck portable from front and rear
- Heavy duty construction
- Pre-stretches film up to 300%
- Positive, non-slip chain drive
- PLC control
- Octo-Thread carriage allows easy film threading
- Strain gauge film delivery control

General Automated Packaging Services, Inc.

Raptor 525

Semiautomatic Turntable Stretch Wrapper

Specifications

Standard configuration listed below. Please contact your **GAP** sales representative for other available configurations.

Performance

Loads per hour	Up to 35
Rotation speed	12 rpm
Maximum load size	60" x 60" x 85" H (84" dia.)
Maximum load weight	4,000 pounds

Film Delivery System

Film capacity	20" roll width x 10" dia.
Film payout	Strain gauge
Pre-stretch level	250% (optional 100% to 300%)
Force control	Variable
Film threading	Easy thread design
Carriage speed	Adjustable down speed

Controls

Controller	PLC
Operator interface	Push button controls
Load height sensor	Photo eye
Wrap pattern	Fixed top and bottom wrap count. Select 2 & 2, 3 & 3, 4 & 4, 5 & 5. Reinforce wrap feature.
Emergency stop	Mushroom head
Electrical disconnect	Lockable
Electrical enclosure	CSA approved

Power Requirements

Voltage	120 VAC, 15 amp, 1 phase, 60 Hz
---------	---------------------------------

Turntable

Diameter	59.875" (0.5" thick, smooth plate)
Bearing type	Multiple polyurethane covered bearings
Drive system	Spring tensioned chain

Structure

Portability	Lift truck portable front and rear
Machine weight	1,700 pounds
Construction	Heavy duty, welded
Optional ramp	48" W x 61" L
Color	Dark bronze frame, yellow turntable

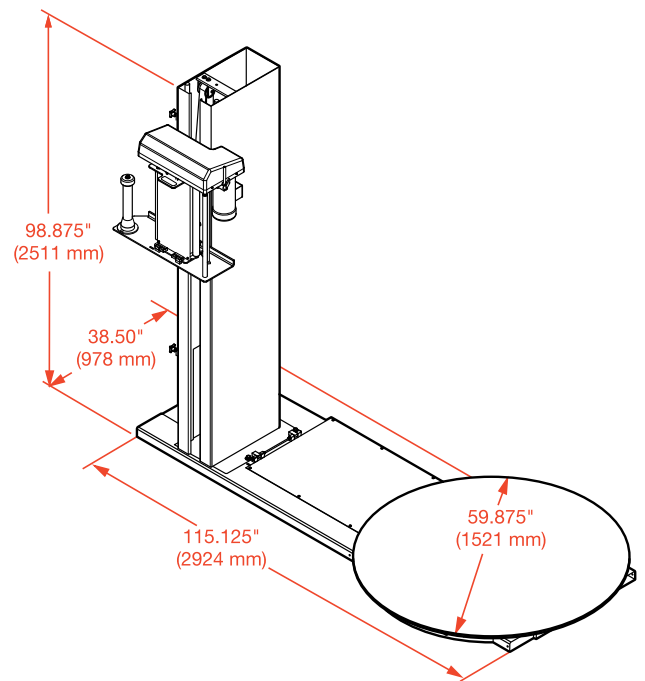

General Automated Packaging Services, Inc.
 95 Cousins Drive, PO Box 82
 Aurora, ON L4G 4J9 Canada
 1-877-427-4275
 general@genautopkg.com
 www.genautopkg.com