

*Turntable Series Stretch Wrappers*

# **RAPTOR<sup>®</sup>**

## **1525CN** *Automatic*



**NEW!**



*Simplified film  
threading with  
improved operator  
ergonomics*

**Octo-Thread**

*Raptor 1525CN with standard  
infeed, turntable and exit  
conveyor (shown without  
standard guarding for clarity).*

*Conveyor-Ready Raptor 1525CR  
also available.*

- Wraps up to 45 loads per hour
- 4,000 pound capacity
- Heavy duty construction
- Pre-stretches film up to 300%
- Ring and pinion drive
- Allen-Bradley PLC with operator interface
- Octo-thread carriage allows ease of film threading
- Strain gauge film delivery control
- 3-1/2" dia. conveyor rollers on 3-3/4" centers

**General Automated Packaging Services, Inc.**

# Raptor 1525CN

## Automatic Turntable Stretch Wrapper

### Specifications

Standard configuration listed below. Please contact your **GAP** sales representative for other available configurations.

#### Performance

Loads per hour	Up to 35
Rotation speed	Adjustable up to 16 rpm
Maximum load size	50" x 54" x 80" H (72" dia.)
Minimum load size	36" x 36" x 28" H
Conveyor elevation	20"
Maximum load weight	4,000 pounds

#### Film Delivery System

Film capacity	20" roll width x 10" dia.
Pre-stretch type	Strain gauge
Pre-stretch level	250% (optional 100% to 300%)
Force control	Variable
Film threading	Octo-Thread design; W film threading pattern
Cut and seal	Controlled impulse cutter and heat sealer

#### Controls

Controller	Allen-Bradley PLC
Operator interface	Touch screen
Load height sensor	Photo eye
Wrap settings	Re-wrap function, overwrap and overlap adjustments
Wrap counters	Independent top and bottom
Cycle counters	Total cycle counter and resettable counter
Emergency stop	Mushroom head
Electrical disconnect	Lockable
Electrical enclosure	CSA approved

#### Power Requirements

Voltage	480 VAC, 30 amp, 3 phase, 60 Hz
Pneumatic	80 psi, 3 CFM (clean, dry air)

#### Turntable

Size	76-1/2" dia.
Bearing type	ring gear
Drive system	Ring and pinion
Conveyor rollers	3-1/2" dia. on 3-3/4" centers; every roller driven; rollers set in pillow block bearings
Transition rollers	Included

#### Structure

Machine dimensions	1525CN: 114" x 192" x 98" H 1525CR: 114" x 95-1/2" x 98" H
Machine weight	1525CN: 5,675 pounds 1525CR: 3,250 pounds
Construction	Heavy duty, welded
Color	Dark bronze

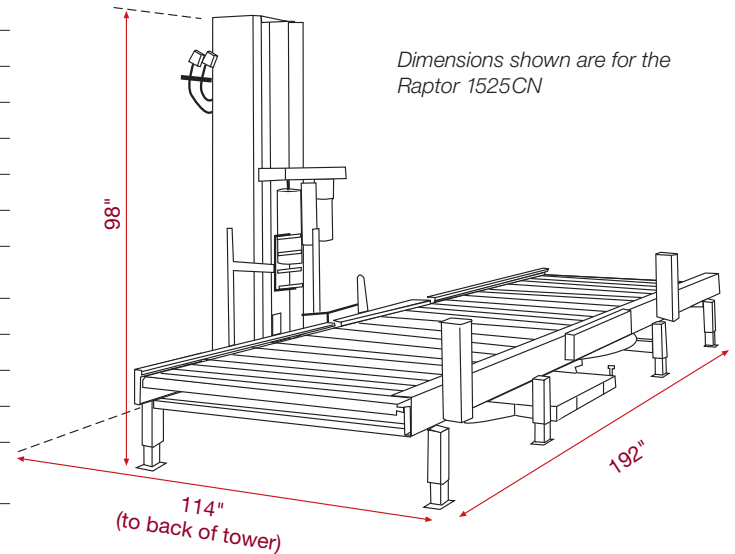

**General Automated Packaging Services, Inc.**  
 95 Cousins Drive, PO Box 82  
 Aurora, ON L4G 4J9 Canada  
 1-877-427-4275  
 general@genautopkg.com  
 www.genautopkg.com