

Rotary Ring Series Stretch Wrappers

OCTOPUS™

303
Automatic



- Wraps up to 60 loads per hour
- Heavy duty construction
- Pre-stretches film up to 300%
- Rotary ring design increases film savings
- Installs over existing conveyor or can be provided with conveyor
- Allen-Bradley PLC control
- Octo-Thread carriage allows easy film threading

General Automated Packaging Services, Inc.

Octopus 303

Automatic Rotary Ring Stretch Wrapper

Specifications

Standard configuration listed below. Please contact your **GAP** sales representative for other available configurations.

Performance

Loads per hour	Up to 60
Maximum load size	48" W x 50" L x 80" H (69" dia.)
Minimum load size	36" W x 36" L x 28" H (film clamp justified)
Maximum load weight	Dependent on conveyor

Film Delivery System

Film capacity	20" roll width x 10" dia.
Film payout	Strain gauge
Pre-stretch level	250% (optional 75% to 300%)
Force control	Variable
Film threading	Octo-Thread design; W film threading pattern
Cut and seal	Controlled impulse cutter and heat sealer

Controls

Controller	Allen-Bradley PLC
Operator interface	Touch screen
Load height sensor	Photo eye
Wrap settings	Re-wrap function, overwrap and overlap adjustments
Wrap counters	Independent top and bottom
Emergency stop	Mushroom head
Electrical disconnect	Lockable
Electrical enclosure	CSA approved

Power Requirements

Voltage	480 VAC, 3 phase, 30 amps
Pneumatic	80 psi, 3 CFM (clean, dry air)

Ring Lift and Rotation

Lift method	Reinforced belt
Lift motor	480 VAC - SEW Eurodrive
Lift control	Variable frequency drive
Rotation method	Belt drive
Rotation motor	480 VAC - SEW Eurodrive
Rotation control	Variable frequency drive

Structure

Machine weight	3,500 pounds
Construction	Aluminum frame and structural steel channel
Color	Structure: Light and dark bronze Ring frame: Yellow

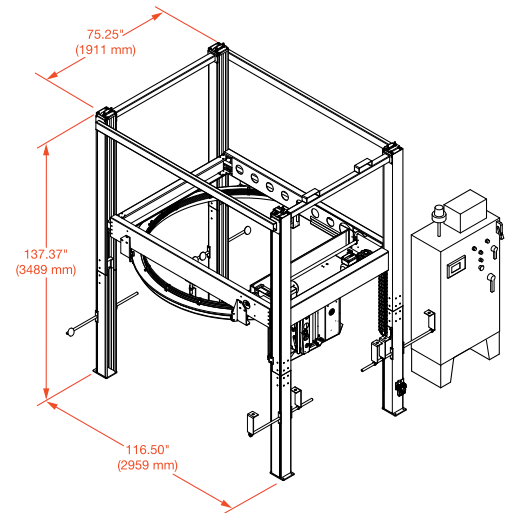

Additional Features

7' high mesh fence around system
Entry gate with automatic shutdown
Upper and lower ring shutdown switches
Internal wrap zone location photo eyes
Infeed and outfeed shutdown photo eyes
Infeed and exit conveyor sequence interlocks: <ul style="list-style-type: none">Customer ready to send loadCustomer ready to receive loadMachine ready to send loadMachine ready to receive load

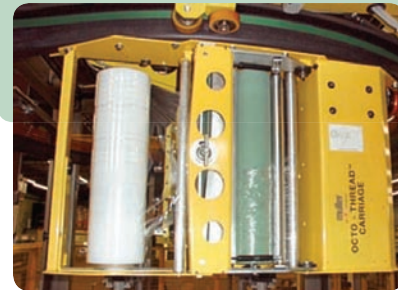

Octo-Thread film carriage

With its rear opening film loading gate, the Octo-Thread film carriage allows for fast, easy and safe film threading. The standard tilting film mandrel allows the operator to load a film roll with greater ease. It also reduces the risk of damaging the film roll during loading.

General Automated Packaging Services, Inc.

95 Cousins Drive, PO Box 82
Aurora, ON L4G 4J9 Canada
1-877-427-4275
general@genautopkg.com
www.genautopkg.com