

## Rotary Arm Series Stretch Wrappers

# COBRA<sup>®</sup>

## 1525A Automatic

**NEW!**



*Simplified film  
threading with  
improved operator  
ergonomics*

**Octo-Thread**



- Wraps up to 30 loads per hour
- No weight limits—loads are wrapped on the floor
- Freestanding design
- Heavy duty construction
- Pre-stretches film up to 300%
- Positive, non-slip V-belt rotation drive
- Allen-Bradley PLC with operator interface
- Octo-Thread carriage allows easy film threading
- Strain gauge film delivery control
- Remote start by pendant

# Cobra 1525A

## Automatic Rotary Arm Stretch Wrapper

### Specifications

Standard configuration listed below. Please contact your **GAP** sales representative for other available configurations.

#### Performance

Loads per hour	Up to 30
Rotation speed	12 rpm
Maximum load size	50" x 50" x 80" H (70" dia.)
Minimum load size	24" x 24" x 28" H (film clamp justified)
Maximum load weight	Floor capacity

#### Film Delivery System

Film capacity	20" roll width x 10" dia.
Pre-stretch type	Strain gauge
Pre-stretch level	250% (optional 100% to 300%)
Force control	Variable
Film threading	Octo-Thread design; W film threading pattern
Cut and seal	Controlled impulse cutter and heat sealer

#### Controls

Controller	Allen-Bradley PLC
Operator interface	Touch screen
Load height sensor	Photo eye
Wrap settings	Re-wrap function; overwrap and overlap adjustments
Wrap counters	Independent top and bottom
Cycle counter	Non-resettable
Emergency stop	Mushroom head
Electrical disconnect	Lockable
Electrical enclosure	CSA approved

#### Power Requirements

Voltage	120 VAC, 20 amps, 1 phase, 60 Hz
Pneumatic	80 psi, 3 CFM (clean, dry air)

#### Rotary Arm

Drive system	Dual V-belt drive
Bearing type	Dual pillow block bearings

#### Structure

Installation	Floor mounted gantry frame
Machine weight	2,400 pounds
Construction	Heavy duty, welded
Color	Dark bronze
Rotating arm color	Yellow

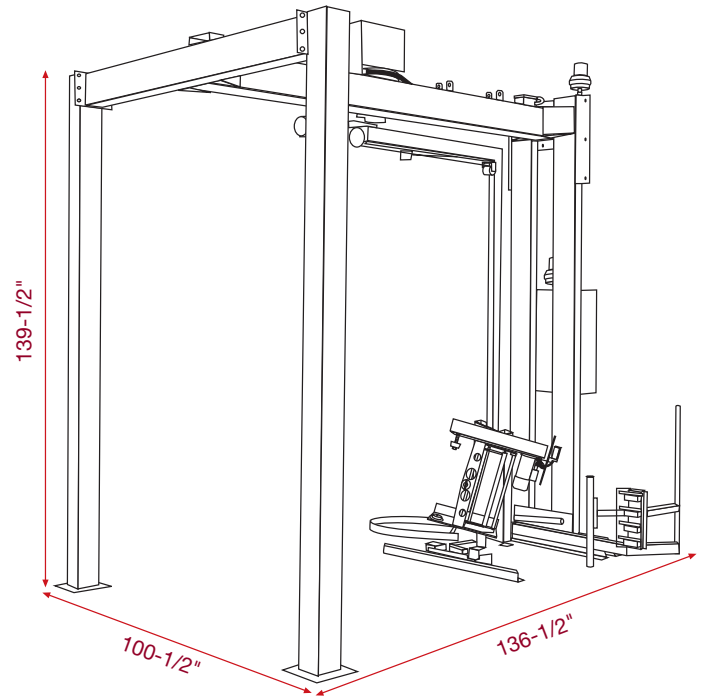

**General Automated Packaging Services, Inc.**  
 95 Cousins Drive, PO Box 82  
 Aurora, ON L4G 4J9 Canada  
 1-877-427-4275  
 general@genautopkg.com  
 www.genautopkg.com